

# STUART POWER LTD RENTAL SOLUTIONS



**POWERING INDUSTRY SOLUTIONS**  
**POWER, PUMPS, LIGHTING AND DISTRIBUTION**





# POWERING INDUSTRY SOLUTIONS NATIONWIDE

## POWER, PUMPS, LIGHTING AND DISTRIBUTION

# STUART POWER LTD

### NORTH WEST DEPOT

Stuart House, Haydock Lane, Haydock Industrial Estate,  
Merseyside, WA11 9UH  
T: 0845 642 1662

### NORTH EAST DEPOT

Middleplatt Road, Immingham, DN40 1AH  
T: 01469 551230

### WEST MIDLANDS DEPOT

Diglis Trading Estate, Navigation Road, Worcester, WR5 3DE  
T: 01905 964499

### EAST ANGLIA DEPOT AND HQ

Stuart House, Hargham Road, Shropham, Norfolk, NR17 1DT  
T: 01953 454540

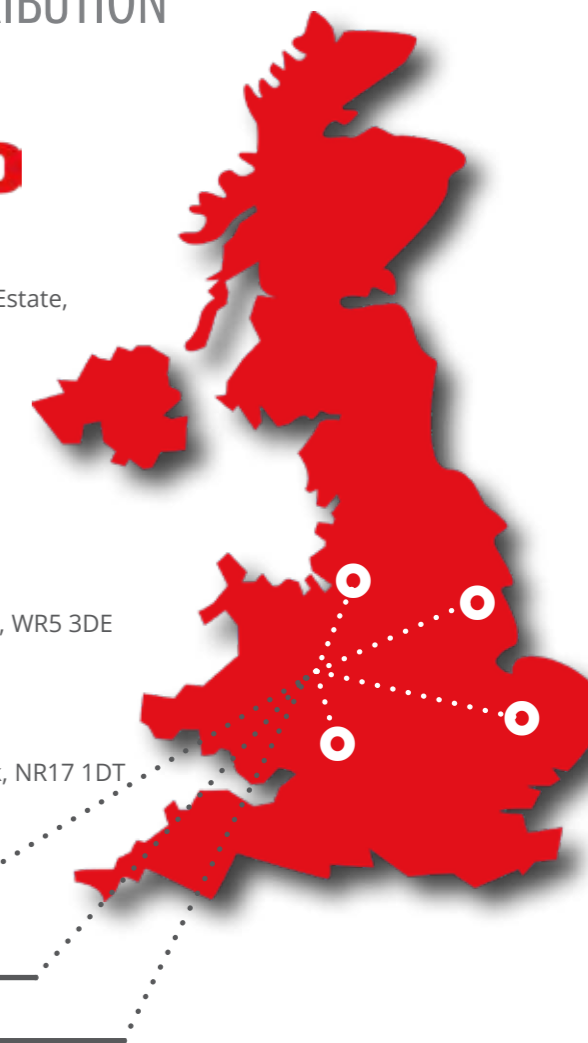

**24/7 EMERGENCY** 365 DAYS A YEAR

**24/7 SUPPORT** 365 DAYS A YEAR

**NATIONWIDE COVERAGE** 365 DAYS A YEAR



CALL OUR EXPERTS



FRIENDLY ADVICE



DELIVERY

### CONTENTS

GENERATORS	P 4-11
Stage V	P 8-9
Hybrid	P 10-11
BATTERY ENERGY STORAGE	P 12-13
TOWER LIGHTS	P 14
Stage V	P 15
FUEL TANKS	P 17-19
POWER ACCESSORIES	P 20-23
ACOUSTIC BARRIERS	P 24
SERVICES	P 25-26
PUMPS	P 27-30
STUART POWER	P 31







## GENERATORS CANOPIED 20kVA TO 850kVA



### KEY FEATURES



FORKLIFT POCKETS



ADJUSTABLE EARTH LEAKAGE\*



EMERGENCY STOP ON CONTROL PANEL AND ENCLOSURE



QUICK-RELEASE FUEL CONNECTIONS



50/60 Hz FREQUENCY ON SELECTED MODELS



DUAL WALL BASE TANK WITH 110% SPILL CONTAINMENT

At Stuart Power, we understand the importance of environmental responsibility. Our fleet of low-emission, fuel-efficient generators and hybrid power solutions help clients reduce their carbon footprint while maintaining reliable power supply.

We are proud to offer environmentally friendly alternatives like battery energy storage systems, hybrid generators, and AdBlue technologies that comply with stringent EU Stage V regulations.

Our generators are fuel efficient, easy to operate and packaged in weatherproof sound-attenuated enclosures providing excellent noise reduction.

#### SIZE kVA

- 20kVA
- 30kVA
- 65kVA
- 110kVA
- 150kVA
- 200kVA
- 275kVA
- 400kVA
- 550kVA
- 800kVA
- 850kVA



### RAPID DEPLOYMENT



\*NOT AVAILABLE ON 20kVA



## ROAD TOW 20kVA TO 150kVA GENERATORS



Our road towable canopied generators are trailer mounted and benefit from our standard features: robust, super silent and fuel efficient. Available from 20kVA to 150kVA, ready for rapid deployment and delivered on transport to suit your location.

#### SIZE kVA

- 20kVA
- 30kVA
- 65kVA
- 110kVA
- 150kVA

## SYNCHRONISING GENERATORS



Utilising the latest Deep Sea control modules on our synchronising generators enables us to provide an intelligent control system for up to 32 gen-sets. Offering configurable inputs and outputs to allow remote monitoring, data logging, generator load demand, sequential start and paralleling and ensures the optimal power solution for each application.

#### SYNCHRONISING OPTIONS

- LOAD SHARE
- AUTO START
- LOAD DEMAND
- PARALLEL
- ISLAND MODE
- BACKUP FUNCTION







## GENERATORS 800kVA TO 2000kVA



Our containerised generators are easy to transport, already mounted on trailers with fuel tanks connected. Emergency power requirements are easily handled by our experienced teams located at each depot. We will have you powered in no time.

These generators are designed using our skilled knowledge and are then custom-built. Available in 20ft, 30ft and 40ft containers, they are super silent and secure. With the additional functionality of synchronisation, we can offer multi-megawatt solutions ideal for large site operations.

Our skilled engineers and account managers can perform site surveys, ensuring we deliver your project correct, on time and on budget. With a range of bulk fuel tanks, cables, load banks and transformers available, we can deliver and install every aspect of your project.

Whether for a planned power project or an emergency outage, you can rest assured we will have the right solution to suit your needs.



SIZE kVA
800kVA
1000kVA
1250kVA
1500kVA
1850kVA
2000kVA

### APPLICATIONS INCLUDE:



## SECURE CONTAINER GENERATORS



### IDEAL INDUSTRIES INCLUDE:

SHIPPING

CONSTRUCTION

TELECOMS

UTILITIES

PETROCHEMICAL

Our range of secure containerised generators offers site solutions when safety is a concern plus the added environmental benefit of the complete unit being bundled. It is not surprising that more sites are switching to this compact solution. Each container is custom-built with a large fuel tank and is available with open or closed generator canopies.

We also provide site distribution boards, cables, transformers as well as installation to facilitate your site power requirements.

### SAFE AND SECURE



Four lockable door bars, a heavy duty lock box, adjustable cable exits with securing pins, cable clamps and fill/vent pipes fitted with a heavy duty grill means this product symbolises security.

### BENEFITS



NOISE REDUCTION

ENVIRONMENTALLY SAFE

SAFE AND SECURE

### SAFEGEN

Size kVA	Length (mm)	Width (mm)	Height (mm)	Tank Size (l)
20kVA Containerised Set	2991	2438	2591	1500-2000
30kVA Containerised Set	2991	2438	2591	1500-2000
50kVA Containerised Set	3962	2438	2591	1500-2000
65kVA Containerised Set	3962	2438	2591	1500-2000
100kVA Containerised Set	3962	2438	2591	1500-2000
150kVA Containerised Set	6096	2438	2591	1500-2000





# GENERATORS STAGE V



Authorised Dealer

## EU V Compliant Generators

Stage V FG Wilson PRO range are reduced emissions generators that comply with EU Stage V Emissions Regulations.

Expertly engineered to meet stringent emissions standards for mobile applications and clean air zones, these advanced generators deliver reliable power while prioritising environmental responsibility.

Sound attenuated enclosures have excellent noise reduction making them suitable for residential projects and any other application where silent power is a must.



EU V COMPLIANT



FUEL EFFICIENT



REMOTE MONITORING



SCR\* TO REDUCE NO<sub>x</sub>

SIZE (kVA)	FUEL CAPACITY (L)	WEIGHT EMPTY (KG)	WEIGHT FULL (KG)	DIMENSIONS H x W x L (MM)
20	56	689	745	1300 x 918 x 1718
115	518	2009	2527	2076 x 1150 x 2970
200	822	3651	4350	2367 x 1420 x 4085
310	667	4218	4784	2277 x 1514 x 4085
600	1125	6740	7700	2434 x 2040 x 5420

\* SELECTIVE CATALYTIC REDUCTION



# STAGE V TECHNICAL GENERATORS

## Powered by STAGE V

### SCR

#### Selective Catalytic Reduction

A fine spray of AdBlue solution is mixed with exhaust gases. A special ceramic catalyst uses this solution to convert nitrogen oxide NOX into nitrogen and water.

AdBlue is a colourless liquid made up of high-purity urea (32.5%) and deionised water (67.5%)

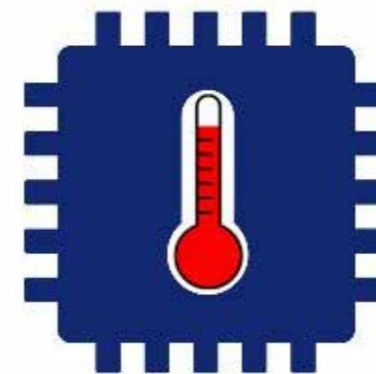
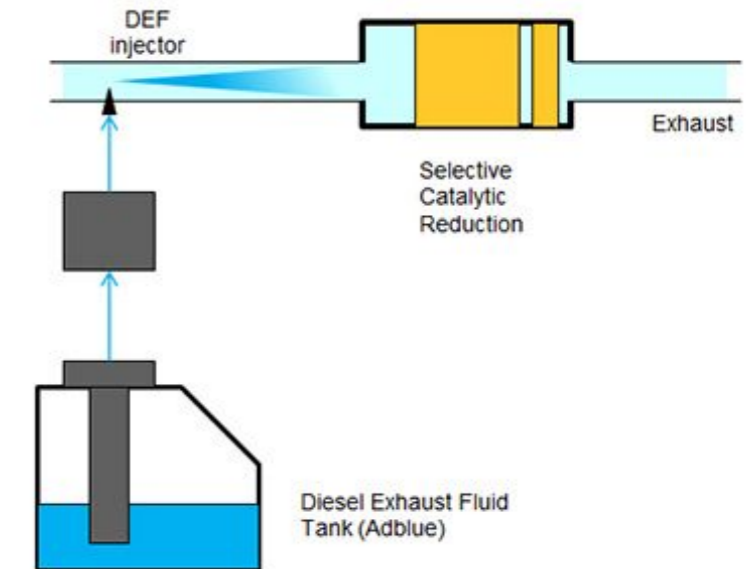

### Thermal Management

Thermal management of the aftertreatment is very important. A DPF requires raised temperatures for the regeneration process to burn off soot particles. Additionally, the selective catalytic reduction process requires raised temperatures for the catalytic reaction and to remove urea deposits.





# GENERATORS HYBRID POWERSAFE



The HybridPowerSafe combines all the benefits of hybrid power with our SafeGen, which is custom designed and built to provide a compact, sound-attenuated, safe and secure option. Our HybridPowerSafe offers an additional environmental layer with the unit being fully bundled.

Custom-built with numerous hybrid socket options. Using an external mounted mains distribution board via direct passthrough many more configurations can be achieved.

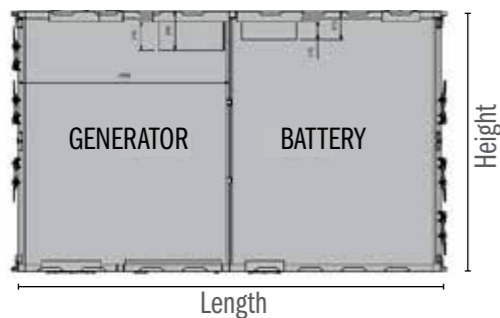

HYBRID POWER SAFE					
Generator	Hybrid	Length (mm)	Width (mm)	Height (mm)	Weight Dry (kg)*
65kVA	30kVA	3955	2438	2736	7560

\*Weight with lube oil, no coolant, no fuel.

**Reduction in run hours\*\***

**67%**

Number of days	27
Fuel consumption per hour	5l
Cost of fuel per litre	£1.75
Normal run hours for this period	648:00
Actual run hours for this period	213:33
Reduction in run hours	434:26

**Reduction in fuel consumed\*\***

**67%**

Conventional Generator Run Time	648:00
Cost (£)	5670.00
Hybrid Generator Run Time	213:33
Cost (£)	1866.00
Fuel Saved (£)	3804.00

**HybridPowerSafe**

**reducenoisefuelpollution**



# GENERATORS TECHNICAL DATA

## GENERATOR RENTAL RANGE 20kVA TO 2000kVA

Size kVA	Length (mm)	Width (mm)	Height (mm)	Weight Dry (kg)	Fuel Capacity (l)	50% Load (l/hr)	75% Load (l/hr)	100% Load (l/hr)
20kVA	1685	950	1485	730	45	2.9	3.9	5.3
30kVA	2102	970	1525	1002	161	4	5.7	7.4
45kVA	2300	1120	1525	1293	219	5.8	7.5	9.2
65kVA	2300	1120	1525	1319	219	7.8	12.3	16.3
PRO100kVA	2770	1120	1847	2027	410	14.6	20.4	23.5
110kVA	2770	1120	1525	1744	250	12.9	18.9	23.8
PRO150kVA	3520	1120	2226	2547	590	16.4	24.7	33.4
150kVA	3520	1120	1815	2158	349	19.9	28.1	33.5
200kVA	3894	1300	1996	2944	550	26.8	37.6	48.7
275kVA	4300	1300	2259	3800	757	27.50	41.25	55.00
PRO300kVA	4065	1400	2124	3880	592.6	33.8	47.3	62.5
400kVA	4930	1658	2317	4655	887	36.2	53	69.6
550kVA	4930	1658	2317	5230	887	58.7	80.7	104
800kVA	5894	2335	2670	7773	1444	67.86	101.79	135
Sizes below reflect on-trailer dimensions								
800kVA	13600	2400	4200			Contact Us		
1000kVA	13600	2400	4200			Contact Us		
1250kVA	13600	2400	4200			Contact Us		
1500kVA	13600	2400	4200			Contact Us		
1850kVA	13600	2400	4200			Contact Us		
2000kVA	13600	2400	4200			Contact Us		

All weights and measurements are for indicative purposes only. The information contained above is for guidance only and is subject to change without notice or liability. All information is provided in good faith.







## INTELLIGENT BATTERY ENERGY STORAGE SYSTEM



Stuart Power's fleet of Intelligent Battery Energy Storage Systems (IBESS) help to reduce fuel costs, meet sustainability targets and reduce CO<sub>2</sub> and NO<sub>x</sub> emissions.

Similar to hybrid car technology, these battery units have an intelligent control system that manages variable loads, allowing the generator to switch off during periods of low power consumption i.e. overnight.

The batteries will supply power silently during this period and the generator will automatically restart when the demand is high, or the batteries become depleted.

INTELLIGENT BATTERY ENERGY STORAGE SYSTEM					
kVA	kWh	Length (mm)	Width (mm)	Height (mm)	Weight (mm)
45	80	2240	1160	2118	2000

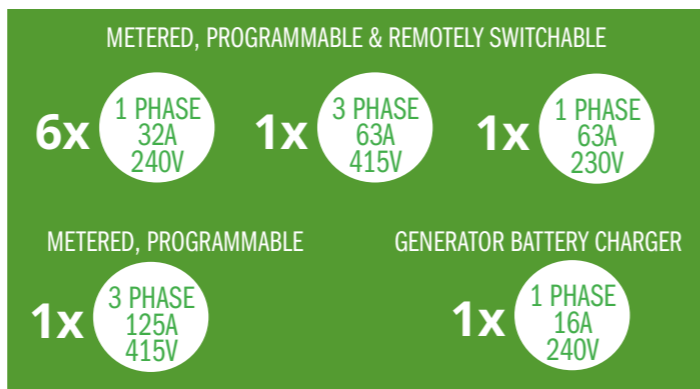

### "How long will the unit last on a single charge?"

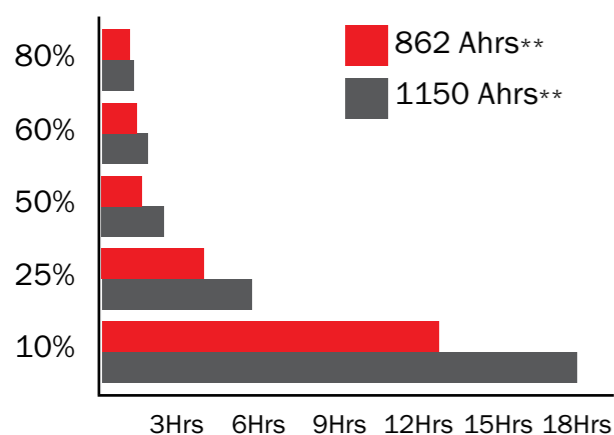

This is the most common question asked; and the answer depends entirely on how fast the stored energy is used up. Power usage is not always steady so it's difficult to be specific but, as a guide, this chart shows the typical duration based on average power use as a percentage of rated output.

Our teams will be able to answer any questions.

\*\* Data shown is for a 30kVA Hybrid Power Unit



## ERICA ENERGY MANAGEMENT & CONTROL SYSTEM



All our Intelligent Battery Energy Storage Systems come with an integral energy management and control system. It gives you access to live energy data and advanced, downloadable reporting.

Energy data is available by socket, identifying when and where energy is used which can highlight opportunities to reduce energy wastage, costs and carbon emissions.

The energy saving scheduler allows you to set on and off times for each day per switchable socket. By using the scheduler appropriately large savings in power can be made on-site, especially if no weekend working is needed.

### BENEFITS

- ✓ MEASURE & UNDERSTAND SITE POWER USAGE
- ✓ MANAGE POWER TO REDUCE USAGE
- ✓ REDUCE DIESEL USAGE
- ✓ IMPROVE HYBRID BATTERY PERFORMANCE
- ✓ RECORD FAULT EVENTS TO AID MAINTENANCE
- ✓ AIDS CARBON REPORTING

### INDUSTRIES

CONSTRUCTION

EVENTS

RAIL

TELECOMS

UTILITIES

PUMPING

FILM & TV



LIVE DATA MONITORING



TURN POWER ON & OFF VIA DASHBOARD



DIFFERENT PROFILES & LABELS FOR EACH CONNECTION



# TOWER LIGHTS



## V20 PERKINS 402D-05 ENGINE

Voltage (V)	48V DC
LED lamps total power (W)	4 x 320W
Total lumen (lm)	167300
Illuminated area (m2)	4500
Fuel tank capacity (L)	100
Control panel-Digital controller	GTL01 DC
Weight (kg)	980
Dimensions LxWxH (mm)	2200x1400x2440
Dimensions (Deployed) LxWxH (mm)	2200x1850x8500
Avg. sound pressure dB(A) @ 7m	58
Wind speed resistance (km/h)	110
Running time	167 hours



One of the lowest sound pressure levels in the industry: only 58 dB(A) at 7 metres.

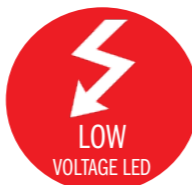

The floodlights are powered with 48 Volts. No more high voltages on external cables. Safety is a must!



Thanks to the V20's fuel-saving features such as the small engine and the LED lamps, this model can run up to 167 hours without refuelling.



Three doors for wider access. Two compass-top doors with wing shape provide complete access to the engine for safe and convenient maintenance.

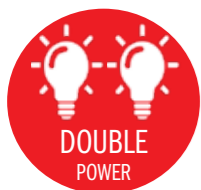

Connect two V20s and run just one engine.



The special shape of the adjustable stabilisers allows the operator to level the V20 in a few seconds.



# STAGE V TOWER LIGHTS

## Powered by STAGE V

The V20 Kubota has all the features of the V20 Perkins with the Kubota Z482 engine which meets Stage V requirements

## V20 KUBOTA Z482

Digital controller	GTL01
LED Lamps total power (W)	4 x 320W
Total lumen (lm)	167300
Illuminated area (m2)	4500
Fuel tank capacity (L)	100
Lifting system	Hydraulic
Weight (kg)	980
Dimensions LxWxH (mm)	2200x1400x2440
Dimensions (Deployed) LxWxH (mm)	2200x1850x8500
Avg. sound pressure dB(A) @ 7m	58
Wind speed resistance (km/h)	110
Running time	143 hours



EU V COMPLIANT



REDUCED FUEL CONSUMPTION



REDUCED EMISSIONS





## TECHNICAL DATA CABLE

### H07RN-F RUBBER CABLE CURRENT CARRYING CAPACITIES

Cable Description (mm)	Current Capacity (Amps)	Overall Diameter (mm)	Cable Weight (kg/m)
2.5mm 3 Core 1ph	29	11.48	0.210
6mm 3 Core 1ph	52	14.78	0.390
16mm 3 Core 1ph	86	23.31	1.031
35mm 3 Core 1ph	140	30.2	1.907
2.5mm 5 Core 3ph	29	14	0.320
6mm 5 Core 3ph	52	18.2	0.630
16mm 5 Core 3ph	86	28.2	1.530
35mm 5 Core 3ph	140	37.2	3.590
35mm Single Core	192	14.6	0.520
50mm Single Core	240	17.2	0.720
70mm Single Core	297	19.35	0.970
95mm Single Core	354	22.2	1.240
120mm Single Core	414	24.3	1.540
150mm Single Core	476	25.9	1.890
185mm Single Core	540	29.7	2.300
240mm Single Core	645	31.5	2.940

ph = Phase  
The above technical data is for indicative purposes. The information contained above is for guidance only and is subject to change without notice or liability. All information is provided in good faith.

### ELECTRICAL FORMULA

To Find	Single-Phase	Three-Phase
Kilowatts	$\text{Amps} \times \text{Volts} \times \text{PF} / 1000$	$\text{Amps} \times \text{Volts} \times 1.732 \times \text{PF} / 1000$
kVA	$\text{Amps} \times \text{Volts} / 1000$	$\text{Amps} \times \text{Volts} \times 1.732 / 1000$
Amperes KW known	$(\text{KW} \times 1000) / (\text{Volts} \times \text{PF})$	$(\text{KW} \times 1000) / (1.732 \times \text{Volts} \times \text{PF})$
Amperes kVA known	$\text{kVA} \times 1000 / \text{Volts}$	$(\text{kVA} \times 1000) / (1.732 \times \text{Volts})$

PF = Power Factor (0.8)



## REMOTE FUEL MONITORING

### SMARTGUARD REMOTE MONITORING

SmartGuard is a cost effective fuel tank level monitor. The SmartGuard SG6-P is a remote device featuring an integrated capacitive probe for measuring fuel levels.

Level data is collected wirelessly using the mobile phone network and can be viewed and downloaded from a browser or via an API.

SMS and email alarms are server-generated for key events.

Should a tanks fuel level fall because of theft or a bad leak, the unit sends an alarm text message to the tank owner. At the same time data is sent to the internet and alarms are emailed to further recipients.



Submersible liquid level monitoring +/- 0.05% Accuracy







## FUEL TANKS

### FUEL TANKS

Our fuel storage tanks range from the portable Fuel Kaddi (100l) up to 64,000l bunded tanks. In addition to the standard fuel tanks listed below, we can supply a choice of hand or electric pumps.



### FUEL TANKS

LITRES	TYPE	DESCRIPTION AS STANDARD	DIMENSIONS L x W x H (mm)
105	Static	Comes with hand pump	TBC
1,000	Static and Mobile	6m of quick-release fuel pipes	1213 x 1213 x 1410
2,000	Static and Mobile	6m of quick-release fuel pipes	2300 x 1150 x 1320
3,000	Static and Mobile	6m of quick-release fuel pipes	2300 x 1550 x 1320
4,500	Static	6m of quick-release fuel pipes	TBC
6,000	Static	6m of quick-release fuel pipes	TBC
9,000	Static	6m of quick-release fuel pipes	TBC
10,000	Static	-	TBC
26,000	Static	-	TBC
64,000	Static	-	TBC



## FUEL TANKS

### FUEL IBC

Fuel tanks available in 1,000, 2,000 and 3,000L

Key features include:

- 110% bunded (steel in steel) to ensure compliance with PPG2
- Removable top, for access to inner tank & cleaning
- Gas sprung lockable lid
- Galvanised corner protectors
- AdBlue IBCs for Stage V generators



CAPACITY (L)	LENGTH (MM)	WIDTH (MM)	HEIGHT (MM)	WEIGHT EMPTY (KG)	WEIGHT FULL (KG)
1000	1110	1110	1270	290	1100
2000	2230	1110	1270	862	2662
3000	2230	1110	1270	991	3691

All weights and measurements are for indicative purposes only. The information contained above is for guidance only and is subject to change without notice or liability. All information is provided in good faith.







## POWER ACCESSORIES

### DISTRIBUTION BOARDS

Power distribution is another one of our key strengths. Our vast range of electrical distribution boards is available in both single-phase and three-phase. With such a varied range, we can ensure that any project is safely supported, with inputs and outputs from hardwire, powerlock, 125amp three-phase right down to 16amp single-phase.

Metal site boards are available from 32amp to 3200amp with customisable sockets to suit your needs.



DD125-1



DD125-2



DDJB-1



DDPL-1



DDPL-2



## POWER ACCESSORIES

### DISTRIBUTION BOARDS



### TRANSFORMERS



Step-down 110v site power transformers, available in ratings 3kVA to 20kVA, fitted with 16amp & 32amp sockets and configured with either 240v or 415v input.

Step-up high voltage transformers are available upon request.

#### TRANSFORMERS

Size	Incoming	Outgoing	Height	Width	Depth
415v - 110v Step-down	32amp 3ph	2 x 32amp 110V 4 x 16amp 110V	685mm	505mm	500mm
415v - 690v Step-up	125amp 3ph	1 x 125amp 690V	800mm	1000mm	600mm

### AMF ATS PANELS



Load transfer panels are housed within a robust metal frame, with lifting eye and forklift pockets for ease of site movement. These provide a practical, automatic switching facility for your standby application in the event of a primary power failure.

Our range of AMF panels go up to 3200amps.





## POWER ACCESSORIES

### CABLE RAMPS

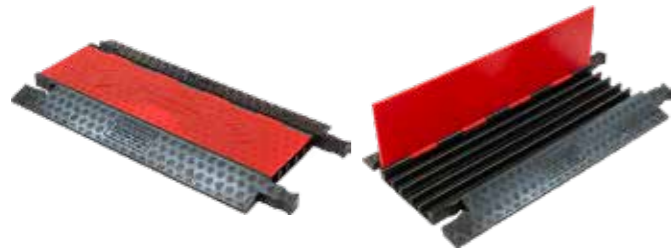

5 channel heavy-duty cable ramps are suitable for many applications, providing protection to cables and hoses from vehicular and pedestrian damage.

#### CABLE RAMPS

CABLE RAMP	LENGTH	WIDTH	CHANNEL SIZE
Five-channel, heavy-duty	900mm	500mm	38mm x 5

### JUNCTION BOXES AND LUGITS



Our compact junction boxes provide safe and secure connections for your on-site requirements. Suitable for 5 single core up to 240mm cable.



LUGIT is a safe and efficient alternative to the traditional junction box, creating temporary IP67 connections (when assembled correctly) or extensions to single core power cables that are terminated with copper lug terminals. Suitable for up to 300mm single core cable.

### CABLES



We have extensive stock of all types of cable, including plug and socket, powerlock cables, lug end, multi and single core cable, providing for all your cabling needs. All our cable is H07RN-F double insulated, conforms to BS EN 7919 is flexible, and has the capacity to withstand our changeable weather conditions.



Our electrical distribution and cabling rental equipment undergoes a rigorous test and inspection regime prior to despatch.



## POWER ACCESSORIES

### LOAD BANKS



Generator load bank testing is essential to avoid your generator failing when you need it most.

We recommend load bank testing that will improve engine performance by clearing deposits in the combustion chamber, injector nozzles, piston rings, turbocharger, and exhaust system.

#### LOAD BANKS - AC RESISTIVE

KW	RATING
20KW to 3125KW	415V, 50Hz, 3ph

#### LOAD BANKS - RESISTIVE/REACTIVE

kVA	RATING
400kVA to 3250kVA	415V, 50Hz, 3ph

LET US HELP YOU MAKE THE RIGHT CHOICE



## EXTENSIVE GENERATOR SUPPORT SOLUTIONS IN JUST ONE CALL



## ACOUSTIC BARRIERS

When noise is generated on site, the acoustic barrier membrane will absorb and reduce the degree of noise pollution. The barriers are lightweight and flexible, allowing for a simple and easy installation.

### TEMPORARY FENCING

Need security and perimeter boundaries? We stock Temporary Fencing & accessories to enable you to secure your project.



**SOUND**

**How it works**  
It has been developed using a composite of fibres that both absorbs and controls noise.

When noise is generated on site, the acoustic barrier membrane will absorb and reduce the degree of noise pollution.

**3 PER PANEL**



## FUEL MANAGEMENT SERVICES



We know the importance of keeping a site/project running at all times, so we offer a dedicated fuel management system that is run in-house.

Our teams will measure your fuel consumption effectively with the added benefit of ongoing checks. Our checks will monitor your power needs and should they increase or fall, we will offer advice accordingly.

Having our own specialised fleet of vehicles enables us to control deliveries and offer a 24/7 emergency refuelling service.

Regardless of where your generator or tank is located (UK Mainland) we have the solution for accessible deliveries, keeping your project fuelled and removing any unnecessary downtime due to running out of fuel.



IN-HOUSE FUEL MANAGEMENT



COMPETITIVE PRICING



REMOTE MONITORING



EMERGENCY 24/7 FUEL



REGULAR INVOICING



FULLY BUNDED TANKS



ADR COMPLIANT



## ALTERNATIVE FUELS

LOOKING FOR AN ALTERNATIVE TO TRADITIONAL DIESEL?

Talk to our team of specialists to see how we can assist your project/business/event in making the change.

REDUCE EMISSIONS

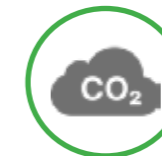

REDUCE POLLUTION







## SERVICES INSTALLATIONS

Our dedicated account managers are experienced in delivering full turnkey solutions.

These are carried out by our certified electricians and engineers and range from site survey through to design and installation.

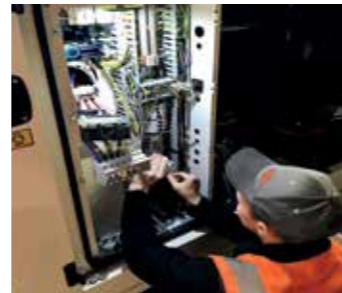

## REMOTE MONITORING

Our in-house remote monitoring system uses the latest technology available. With app solutions you will be able to produce detailed reports, and set up and monitor alerts for your generators anytime, anywhere.

We also offer GPS tracking, giving you an additional layer of security.



DSEGenset®



## SPECIALISED LOGISTICS

Our range of in-house transport solutions is all ADR-compliant and FORS-accredited. They include front and rear mounted cranes across various vehicle types with crane lifting capacity from 23T/M to 65T/M, artic trailers, tractor units and 4x4s.

Our friendly professional drivers will connect the fuel tanks and provide a demonstration to get you started.



## 24/7

Keeping everything under one roof means we have total control, enabling us to offer a genuine dedicated 24/7 service. Emergency equipment, fuel, an engineer and logistics - we have it covered.



## PUMPS



### GENERAL PURPOSE PUMPS



Diesel-engine powered driven multi-purpose, reliable pumps, mounted on either two- or four-wheeled tow trailers. Available as open canopy, silent or electric motor driven. Fuel tanks and cam couplings are available for all of the following. An ideal contractor's pump.

#### GENERAL PURPOSE PUMPS

SIZE	DESCRIPTION	MAX FLOW	MAX HEAD
3" (75mm)	SP80 contractors pump	90 (m <sup>3</sup> /h)	24m
4" (100mm)	SP100 contractors pump	136 (m <sup>3</sup> /h)	28m
4" (100mm)	SP100M contractors pump	160 (m <sup>3</sup> /h)	40m
6" (150mm)	SP150 contractors pump	320 (m <sup>3</sup> /h)	35m
6" (150mm)	SP150M contractors pump	400 (m <sup>3</sup> /h)	40m
8" (200mm)	SP200 contractors pump	400(m <sup>3</sup> /h)	49m
12" (300mm)	SP300M contractors pump (SKID BASE ONLY)	1200 (m <sup>3</sup> /h)	20m
3" (75mm)	Hilta D5 diaphragm pump. Site trailer.	22.5 (m <sup>3</sup> /h)	12m

LET US HELP YOU MAKE THE RIGHT CHOICE



### XYLEM GODWIN PUMP RANGE



These rental pumps offer a differentiated solution with proven technology, providing an environmentally friendly solution, with full liquid containment, excellent fuel savings and sound-attenuated canopies.

#### XYLEM GODWIN PUMP RANGE

SIZE	DESCRIPTION	MAX FLOW	MAX HEAD
4" (100mm)	CD100M Hush-Pac	230 (m <sup>3</sup> /h)	38m
6" (150mm)	CD150MT Hush-Pac	425 (m <sup>3</sup> /h)	35m
4" (100mm)	HL80M Hush-Pac	104 (m <sup>3</sup> /h)	8.5m
6" (150mm)	HL125M	299 (m <sup>3</sup> /h)	134m
6" (150mm)	HL150M	374 (m <sup>3</sup> /h)	148m
8" (200mm)	HL200M	635 (m <sup>3</sup> /h)	117m

godwin   
a xylem brand



## PUMPS

## ELECTRIC SUBMERSIBLE PUMPS



Electric submersible pumps from Tsurumi, Flygt and Pumpex. Ideal for quarrying and mining applications. Submersible pumps are also available to purchase directly.

## ELECTRIC SUBMERSIBLE PUMPS

SIZE	DESCRIPTION	Supplied With
2"(50mm)	Weda L164 (110V) - 1ph	20m of cable
2" (50mm)	Flygt B2050-B2051 - 1ph	20m of cable
2" (50mm)	Tsurumi LB750 - 3ph	20m of cable
2" (50mm)	Flygt 2052 - 3ph	20m of cable
3" (75mm)	Flygt B2066 - 3ph	20m of cable
3" (75mm)	Flygt B2102 HT - 3ph	20m of cable
4" (100mm)	Flygt B2102 LT/MT - 3ph	20m of cable
4" (100mm)	Flygt B2125 HT - 3ph	20m of cable
4" (100mm)	Flygt B2201 HT - 3ph	20m of cable
6" (150mm)	Flygt 2125	20m of cable
6" (150mm)	Flygt 2151	20m of cable
6" (150mm)	Pumpex 3000	20m of cable
6" (150mm)	Flygt 2201 MT	20m of cable
6" (150mm)	Tsurumi LH-675	20m of cable
8" (250mm)	KSB 500MM	20m of cable
8" (250mm)	Flygt B2250	20m of cable

## SEWAGE PUMPS



Pumps and mixers from Flygt and Pumpex.

## SEWAGE PUMPS

SIZE	DESCRIPTION	Supplied With
2" (50mm)	Flygt Grinder	Free-standing base + 10m cable
3" (75mm)	Flygt CS 3085	Free-standing base + 10m cable
4" (100mm)	Flygt CS 3102 3140	Free-standing base + 10m cable
4" (100mm)	Flygt CS 3127 HT	Free-standing base + 10m cable
4" (100mm)	Flygt CS 3152 HT	Free-standing base + 10m cable
6" (150mm)	Flygt CS 3127 MT	Free-standing base + 10m cable
6" (150mm)	Flygt CS 3151 3152	Free-standing base + 10m cable
6" (150mm)	Flygt CS 3170	Free-standing base + 10m cable
6" (150mm)	Flygt CS 3300 HT	Free-standing base + 10m cable
6" (150mm)	Pumpex HT	Free-standing base + 10m cable
8" (200mm)	Flygt 3127 LT	Free-standing base + 10m cable
8" (200mm)	Flygt CS 3200 3201	Free-standing base + 10m cable
8" (200mm)	Flygt 3300 LT	Free-standing base + 10m cable
8" (200mm)	Flygt CS 3300 MT	Free-standing base + 10m cable
24"(600mm)	Flygt Mixers	Free-standing base + 10m cable

## FIRE PUMPS



We offer a wide range of fire fighting pumps with flexible hire rates. Available immediately on a 24-hour call-out basis, as a standby for your existing fire protection system or on a long-term rental contract.

## FIRE PUMPS

SIZE	DESCRIPTION	MAX FLOW	MAX HEAD
6" (150mm)	Fire Pump	3,050 (l/min)	65m
8" (200mm)	Fire Pump	5,500 (l/min)	90m
10" (250mm)	Fire Pump	9,000 (l/min)	70m

## HIGH HEAD FIRE PUMPS

SIZE	DESCRIPTION	MAX FLOW	MAX HEAD
3" (75mm)	High Head Fire Pump	7,000 (l/min)	50m
4" (100mm)	High Head Fire Pump	8,400 (l/min)	90m

## ELECTRIC FIRE PUMPS

SIZE	DESCRIPTION	MAX FLOW	MAX HEAD
6" (150mm)	Electric Fire Pump	2,440 (l/min)	132m

## PUMPS



## HIGH HEAD PUMPS



High Head pumps offer excellent performance with solids handling capability and hard-wearing materials.

## HIGH HEAD PUMPS

SIZE	DESCRIPTION	MAX FLOW	MAX HEAD
3" (75mm)	High Head Pumps - Acoustic and non acoustic	120 (m <sup>3</sup> /h)	90m
4" (100mm)	High Head Pumps - non acoustic	180 (m <sup>3</sup> /h)	110m
6" x 4"	High Head Pumps - non acoustic	325 (m <sup>3</sup> /h)	85m
6" x 6"	High Head Ultra Pump	430 (m <sup>3</sup> /h)	160m
6" x 6"	High Head Pumps - non acoustic	500 (m <sup>3</sup> /h)	93m
6" x 6"	High Head Pumps - Hard Iron	540 (m <sup>3</sup> /h)	94m
8" x 6"	High Head Ultra Pump	870 (m <sup>3</sup> /h)	98m
8" x 6"	High Head Pumps - non acoustic	665 (m <sup>3</sup> /h)	140m

LET US HELP YOU MAKE THE RIGHT CHOICE







## PUMP ACCESSORIES

### HOSE AND ANCILLARY EQUIPMENT



Layflat, poly pipe and wire-armoured hose to hire alongside your pump.

### HOSE AND ANCILLARY EQUIPMENT

SIZE	DESCRIPTION
2" (50mm) to 8" (200mm)	Wire-armoured Suction and Delivery - 6m and 3m Lengths
2" (152mm)	Agriflex Type Heavy Duty PVC Hose 20m and 6m Lengths Suction
2" (50mm) to 6" (152mm)	Medium Duty PVC Hose Suction 6m and 3m Lengths
2" (50mm) to 8" (200mm)	Plain End PVC Suction Hose 9m and 30m Lengths
2" (50mm) to 12" (250mm)	Polyethylene (PE) Poly Pipe - Discharge Hose 3m and 6m Lengths
2" (50mm) to 8" (200mm)	Layflat Discharge Hose 25m, 50m and 100m Lengths
2.5" (63mm)	Duraline Fire Hose 20m Lengths
2" (50mm) to 8" (152mm)	Bauer Couplings, Threaded BSP, Flange, M/F/ Complete Sets, 90° Bend, Hose Tail, Reducer, Enlarger, O'rings, Large Bore Coupling, End Cap Y-Union, Strainers, Bend Clamps, Worm Drive Clamps, Steel Spiral PVC Bend Clamp
1" (32mm)	MDPE Pipe, Compressor Adaptor, Compression Elbow, Valve and Clamps
6" (152mm)	Slurry Tanks Fittings, Bauer MZ Flange, Flange Adaptor, Valves and Gaskets

### STARTER PANELS



A full range of motor starter panels. Direct On Line (DOL), Star Delta and Soft starters are all available for your rental needs.

### DOL STARTERS (DIRECT ON LINE)

MODEL	DESCRIPTION
DOL37i-415	37kW Direct On Line Starter
DOL22i-415	22kW Direct On Line Starter

### STAR DELTA STARTERS

SDS55i-415	55kW Star Delta Starter
SDS55-415	55kW Star Delta Starter

### SOFT STARTERS

PSR72i-230	37kW ABB Soft Starter
PSR45i-230	22kW ABB Soft Starter

### SEPARATORS



Separators are based on the need to find a solution to on-site requirements for a successful temporary oil and water separator. The system is based around a number of separation criteria all located in one contained unit. In essence, one oil/water separator utilises four separation stages.

## IN PURSUIT OF EXCELLENCE STUART POWER

Established in 1982, Stuart Power has expanded to become one of the largest privately owned independent power generation rental businesses in the UK.

Recognising that our staff are critical to the overall success of the business, we invest heavily in ensuring that the team are fully trained and qualified to deliver our company values.

The safety of our employees and activities is paramount to the core principles of our business. We are continually investing and developing our practices to support our mission and our accreditation by trusted associations.

In addition to this, we work closely with FG Wilson as part of an ongoing process to ensure continuous improvement, and to respond to the changing needs of our customers.

We develop through adapting to our customers' requirements, and by ensuring that our Sales, Service and Operational activities always provide the most suitable solution.

Our dedicated team of highly skilled and knowledgeable individuals ensure the smooth running of your project and help deliver excellent results.

**STUART GROUP LTD**

T: 01953 454540  
www.stuartgroup.co.uk  
enquiries@stuartgroup.info

**STUART PUMPS LTD**

T: 01953 454540  
www.stuartgroup.co.uk  
enquiries@stuartgroup.info

**Stuart Wells Limited**

T: 01953 454540  
www.stuartwells.co.uk  
enquiries@stuartwells.co.uk



**STUART POWER LTD**

Head Office and East Anglia Depot:  
Stuart House  
Hargham Road  
Shropham  
Norfolk  
NR17 1DT  
T: 01953 454540  
www.stuartpower.co.uk  
enquiries@stuartpower.co.uk  
Power, Pumps, Lighting and Distribution

**CONTACT 0845 642 1662**  
enquiries@stuartpower.co.uk



○ NORTH WEST DEPOT  
Stuart House, Haydock Lane,  
Haydock Industrial Estate, Merseyside  
WA11 9UH  
T: 0845 642 1662

○ NORTH EAST DEPOT  
Middleplatt Road  
Immingham  
DN40 1AH  
T: 01469 551230

○ WEST MIDLANDS DEPOT  
Diglis Trading Estate  
Navigation Road, Worcester  
WR5 3DE  
T: 01386 791830

○ EAST ANGLIA DEPOT AND HQ  
Stuart House, Hargham Road  
Shropham, Norfolk  
NR17 1DT  
T: 01953 454540

**STUART  
POWER LTD**

[www.stuartpower.co.uk](http://www.stuartpower.co.uk)

| 0845 642 1662

| [enquiries@stuartpower.co.uk](mailto:enquiries@stuartpower.co.uk)